

Front Controls and Connections

Each channel has four switches to modify the signal inserted into any of the input jacks.

MIX switch applies the left and right input signals to the mix buss.

GROUND / LIFT switch breaks the audio ground between the input connectors and the XLR output.

MONO /STEREO switch combines the left and right input signals to mono and sends the sum to both outputs. Signals applied to the mix buss are unaffected.

PAD switch applies 20dB of attenuation to the input signal to control source devices with high output levels, if necessary.

TIP-SLEEVE ¼" input jacks allow individual access to the eight channels of high to low conversion and disconnect both the rear panel RCA and the 3.5mm stereo inputs when used.

3.5MM STEREO jacks provide convenient connection of MP3 players and other audio devices that use the 3.5mm format. The tip is wired to the left channel and the ring to the right. Using these jacks disconnects the rear RCA inputs.

MIX OUTPUT MONO/STEREO switch determines whether the mix output is separate left and right signals or a combined mono signal from both jacks.

WARRANTY

This product is guaranteed to be free from defects in materials and workmanship to the original purchaser for a period of 3 years from the date of purchase. Should service be required, return the unit postage prepaid along with the original sales receipt to:

Whirlwind
Attention - Repair
99 Ling Road
Rochester, New York 14612

The warranty on this product shall not apply to defects or damage resulting from abuse, abnormal use or from repairs or modifications performed by anyone other than Whirlwind. If it is determined a manufacturing defect has occurred, Whirlwind will repair or replace the unit at our option and pay the postage back to you.

pcDIQ

four channel stereo line interface

The pcDIQ is a four-channel version of Whirlwind's popular pcDI stereo line interface, in a 1RU rack mount enclosure. Multiple computer audio outputs, MP3 players, CD players or other consumer audio devices can be converted to mic level for mixing in a traditional audio console.

Each of the four channels has unbalanced stereo line level inputs that are converted to left and right balanced, mic level XLR outputs. Input connections include gold plated left and right RCA jacks on the rear panel, with left and right ¼" tip-sleeve jacks and a 3.5mm stereo jack on the front. Plugging a source device into the front panel jacks disconnects the rear panel RCA inputs. Additionally, the eight ¼" inputs allow the pcDIQ to be used as an eight channel direct box to convert line level audio for recording or live performance purposes.

The pcDIQ also features a separate stereo mix buss that combines the four channels into a single stereo mic level, balanced output. Each of the channels of the pcDIQ can be selectively assigned to the mix buss through a switch. The individual channel can be output in mono while the mix buss signal remains in stereo. An additional switch converts the mix buss output from stereo to mono.

whirlwind
whirlwindusa.com

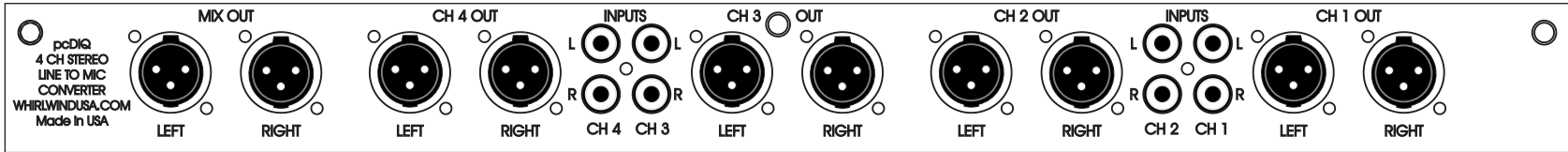

Block Diagram

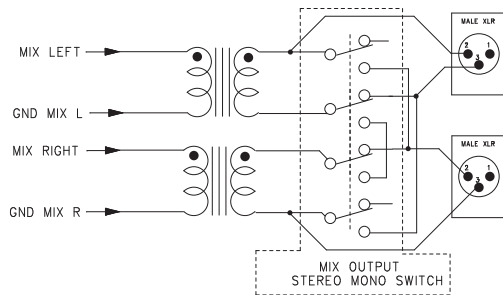
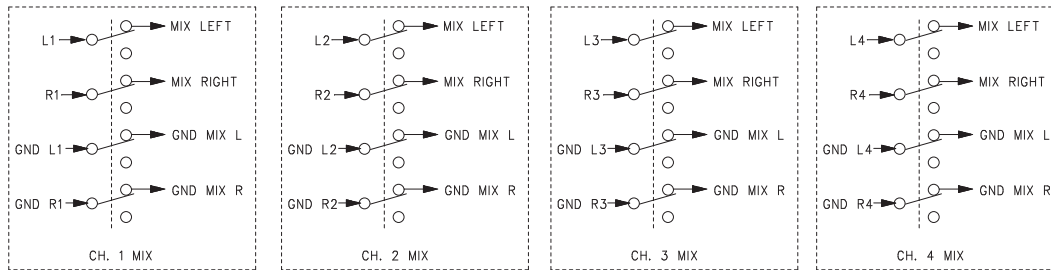
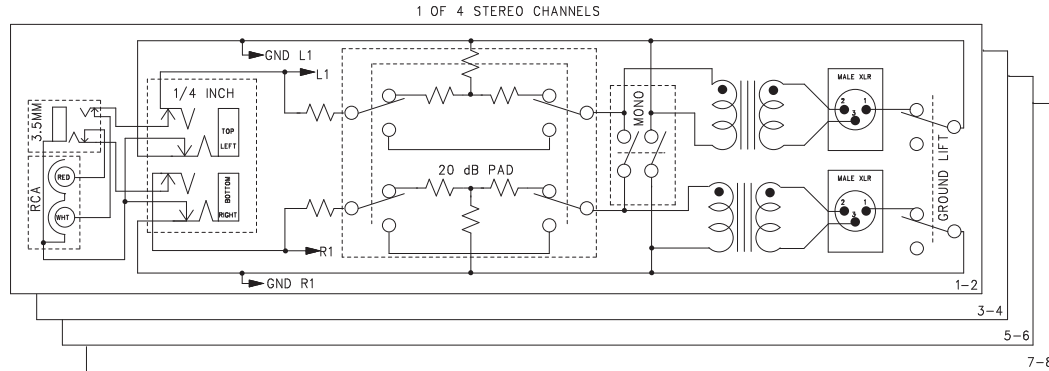

Rear Connections

CHANNEL OUTPUT XLR connectors deliver mic level outputs from the individual channel inputs. The channel MONO/STEREO switches determine if the output is separate left and right signals or a combined mono signal from each jack.

RCA INPUT jacks allow convenient connection of rack mounted source devices with unbalanced outputs. Using the front panel inputs disconnects the rear panel RCA inputs.

MIX OUT XLR connectors deliver the mic level sum of any of the inputs assigned to the mix buss. The mono/stereo switch determines whether the mix output is separate left and right signals or a combined mono signal from both jacks. The balanced output signal is across pins 2 and 3 of the XLRs. The pin 1 ground is permanently lifted from the MIX OUT connectors to reduce the possibility of multiple ground loops in the signal paths.

Specifications

Insertion loss Channel Outputs	21dBV
Insertion loss Mix Out 100 Ohm source Z	33dBV
Frequency Response	± .5dB 20Hz- 20kHz
THD+n % Ch. 1-4 0dBV Input level	.004 @ 1kHz
THD+n % Mix Out 0dBV Input level	.008 @ 1kHz
Phase Shift	< 7° 20Hz- 20kHz
Maximum Input level - Pad off	8.3dBV at 20Hz (1% thd)
Attenuator Pad	20dB
Isolation between input channels	>100dBV @ 2kHz >60dBV @ 20kHz